

目录 CONTENTS

概述、性能范围、型号意义	01
Outline, Performance range, Model meaning	
结构说明	02
About of construction	
结构简图、型谱图	03
Construction drawing, Atlas of style	
性能参数表	04
Performance table	
泵脚座尺寸图表	11
Pump base dimension drawing and table	
进出口法兰尺寸图表	12
In-outlet flange dimension drawing and table	
外形及安装尺寸图表	13
Out-form and installation dimension drawing and table	
水泵装配与拆卸	17
Pump assembly and disassembly	
水泵安装	17
Pump installation	
水泵起、停与运转	18
Pump start, stop and running	
故障原因及排除方法	19
Trouble shooting	
管路损耗参考表	20
pipeline loss	

概述 OUTLINE

IS型泵系单级单吸(轴向吸入)离心泵, 是全国联合设计的节能泵, 它是BA型、B型及其它单级清水离心泵的更新型。优点有: 全系列水力性能布局合理, 用户选择范围宽, 检修方便; 效率和吸程达到国际先进水平。本型泵适用于工业和城市给水、排水, 也可用于农业排灌及供输送清水或物理化学性质类似于清水的其它液体之用, 温度不高于80℃。

IS series single-stage end-suction (axial intake) centrifugal pump is an energy-saving pump designed by teamwork in the whole nation, it is improved on a basis on model BA, B and other single-stage water centrifugal pump. The advantages: its hydraulic capability is distributed reasonably, wide option for user, conveniently check and repair, the efficiency and throw is up to advanced international level. This pump is suitable for industrial and city water supply, water drainage, and widely used for agricultural irrigation, transportation pure water or other liquids whose physical and chemical nature is similar to pure water, and the temperature should not be higher than 80℃.

性能范围 PERFORMANCE RANGE

转 速: 2900r/min和1450r/min;

Speed: 2900RPM and 1450RPM;

进口直径: 50~200mm;

Suction: 50~200mm;

流 量: 6.3~400m³/h;

Flow/Capacity: 6.3~400m³/h;

扬 程: 5~125m。

Head: 5~125m.

型号意义 MODEL MEANING

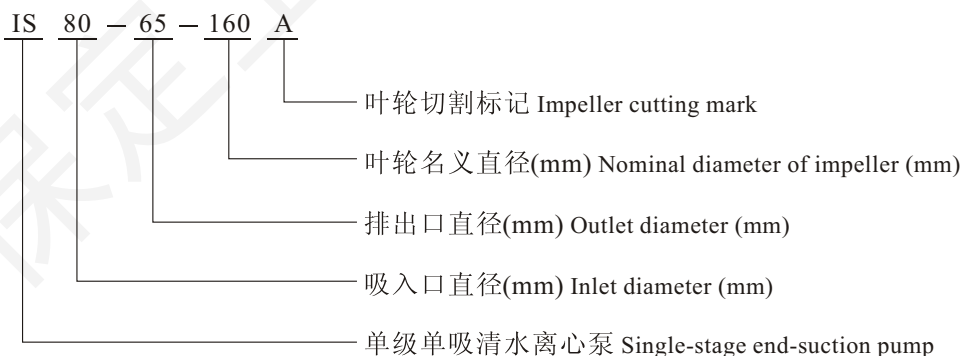

结构说明 ABOUT OF CONSTRUCTION

1、IS型泵系根据国际标准ISO2858所规定的性能和尺寸设计的，主要由泵体、泵盖、叶轮、轴、密封环、轴套及悬架轴承部件等组成。

2、IS型泵的泵体和泵盖的部分，是从叶轮背面处剖分的，即通常所说的后开门结构形式。其优点是检修方便，检修时不动泵体，吸入管路，排出管路和电动机，只需拆下加长联轴器的中心联接件，即可退出转子部件进行检修。

3、泵的壳体(即泵体和泵盖)构成泵的工作室。叶轮、轴和滚动轴承等为泵的转子。悬架轴承部件支撑着泵的转子部件，滚动轴承承受泵的径向力和轴向力。

4、为了平衡泵的轴向力，大多数泵的叶轮前、后均设有密封环，并在叶轮后盖板上设有平衡孔，由于有些泵轴向力不大，叶轮背面未设密封环和平衡孔。

5、泵的轴向密封环是由填料压盖，填料环和填料等组成，以防止进气或大量漏水。泵的叶轮如有平衡，则装有软填料的空腔与叶轮吸入口相通，若叶轮入口处液体处于真空状态，则很容易沿着轴套表面进气，故在填料腔内装有填料环通过泵盖上的小孔，将泵室内压力水引至填料环进行密封。泵的叶轮如没有平衡孔，由于叶轮背面液体压力大于大气压，因而不存在漏气问题，故可不装填料环。

6、为避免轴磨损，在轴通过填料腔的部位装有轴套保护。轴套与轴之间装有O形密封圈，以防止沿着配合表面进气或漏水。

7、泵的传动方式是通过加长弹性联轴器与电动机联结的。泵的旋转方向，从驱动端看，为顺时针方向旋转。

1. IS series single-stage end-suction centrifugal pump is designed according to the capability and size stipulated in the international Standard ISO2858, it is composed of pump body, pump cover, impeller, shaft, ring seal, sleeve and suspended bearing units.

2. The pump body and pump cover in IS series are separated from the back of impeller, that is to say in general, back open structure, whose advantages: convenient overhaul, when checking and repairing, the pump body intake pipe, discharge pipe and motor need not to move, just disassembly the middle connector of extended coupling to quit the rotor units for overhaul.

3. The pump shell (that is pump body and pump cover) forms the workroom of pump. Impeller, shaft and rolling bearing are the rotors for the pump. Suspended bearing units support the rotors in the pump. The rolling bearing stands the radial load and axial force.

4. In order to balance the axial force of the pump, most of the pumps are designed with sealing rings at the front and back of impellers and a balance hole on the rear impeller cap plate. The reverse of impeller is not designed with sealing rings or balance holes if pump axial force is not powerful.

5. The axial sealing ring of the pump is composed of packing gland, packing rings and packing to avoid air admission or severe water leakage. For the impeller with balance hole, the empty chamber with soft packing is straight through with the impeller inlet. If the liquid in the impeller inlet is in vacuum state, the air will enter along the surface of muff easily. Therefore, the packing chamber is fitted with packing ring, which has the seal function when pressure water inside the chamber is led to it through a small hole in the pump cover. For the impeller without balance hole, the packing ring may be neglected in virtue of no existence of air leakage because the impeller back hydraulic pressure is larger than atmosphere one.

6. To avoid abrasion of shaft, the part where the shaft runs through packing chamber is fitted with protective muff. O ring is fitted between muff and shaft to protect against air entering or water leaking along the matching surface.

7. The pump is connected to motor with extending flexible coupling. The pump turns clockwise when you look from the driving end.

IS型单级单吸离心泵

IS Series Single-stage End-suction Centrifugal Pump

结构简图 CONSTRUCTION DRAWING

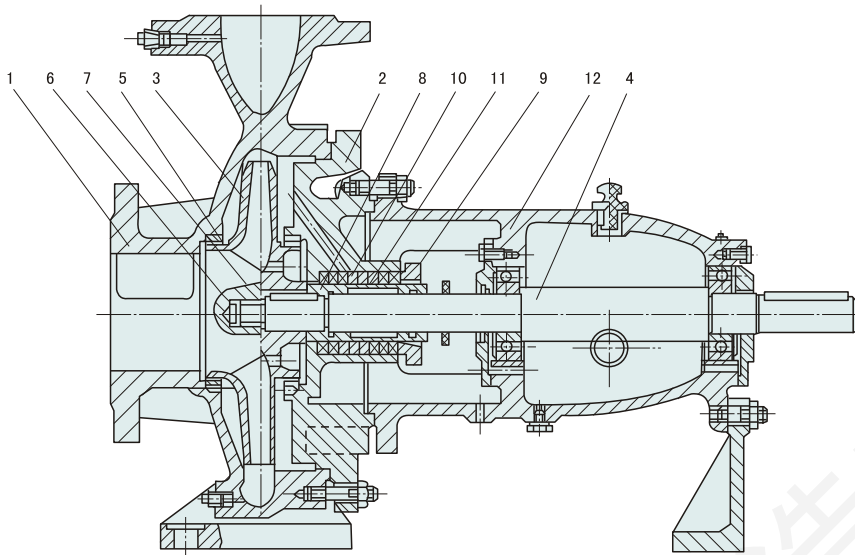

1	泵体 Pump casing
2	泵盖 Pump cover
3	叶轮 Impeller
4	轴 Shaft
5	密封环 Sealing ring
6	叶轮螺母 Impeller nut
7	止动垫圈 Lock washer
8	轴套 Muff
9	填料压盖 Packing gland
10	填料环 Packing ring
11	填料 Packing
12	悬架轴承部件 Pendant bearing assembly

型谱图 ALTAS OF STYLE

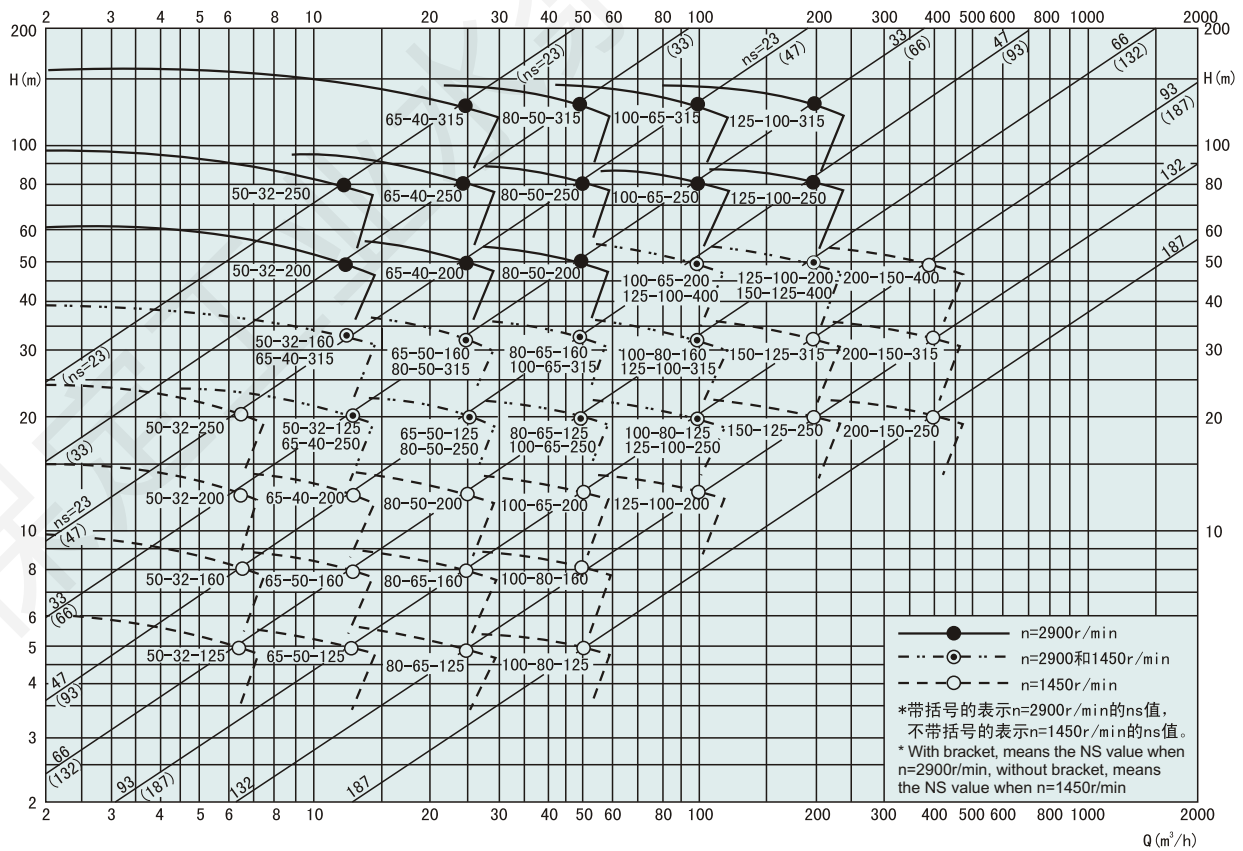

性能参数表 PERFORMANCE TABLE

型号 Model	流量 Capacity		扬程 Head (m)	转速 Speed (r/min)	功率 Power (kW)		效率 Eff. (%)	叶轮名义直径 Impeller diameter (mm)	汽蚀余量 (NPSH) _r (m)
	(m ³ /h)	(L/s)			轴功率 Shaft	电机功率 Motor power			
IS50-32-125	7.5	2.08	22	2900	0.96	2.2	47	130	2.0
	12.5	3.47	20		1.13		60		2.0
	15	4.17	18.5		1.26		60		2.5
IS50-32-125A	11.2	3.1	16	2900	0.84	1.1	58	116	2.0
IS50-32-160	7.5	2.08	34.3	2900	1.59	3	44	158	2.0
	12.5	3.47	32		2.02		54		2.0
	15	4.17	9.6		2.16		56		2.5
IS50-32-160A	11.7	3.3	28	2900	1.71	2.2	53	148	2.0
IS50-32-160B	10.8	3	24	2900	1.41	2.2	50	137	2.0
IS50-32-200	7.5	2.08	52.5	2900	2.82	5.5	38	198	2.0
	12.5	3.47	50		3.54		48		2.0
	15	4.17	48		3.95		51		2.5
IS50-32-200A	11.7	3.3	44	2900	3.16	4	45	186	2.0
IS50-32-200B	10.8	3	38	2900	2.60	3	43	173	2.0
IS50-32-250	7.5	2.08	82	2900	5.87	11	28.5	250	2.0
	12.5	3.47	80		7.16		38		2.0
	15	4.17	78.5		7.83		41		2.5
IS50-32-250A	11.7	3.3	70	2900	6.47	7.5	35	234	2.0
IS50-32-250B	10.8	3	60	2900	5.51	7.5	32	217	2.0
IS65-50-125	15	4.17	21.8	2900	1.54	3	58	130	2.0
	25	6.94	20		1.97		69		2.5
	30	8.33	18.5		2.22		68		3.0
IS65-50-125A	22.4	6.2	16	2900	1.47	2.2	66	116	2.0
IS65-50-160	15	4.17	35	2900	2.65	5.5	54	165	2.0
	25	6.94	32		3.35		65		2.0
	30	8.33	30		3.71		66		2.5
IS65-50-160A	23.4	6.5	28	2900	2.83	4	63	154	2.0
IS65-50-160B	21.7	6	24	2900	2.35	4	60	143	2.0
IS65-40-200	15	4.17	53	2900	4.42	7.5	49	200	2.0
	25	6.94	50		5.67		60		2.0
	30	8.33	47		6.29		61		2.5
IS65-40-200A	23.4	6.5	44	2900	4.92	5.5	57	188	2.0
IS65-40-200B	21.8	6.1	38	2900	4.13	5.5	55	175	2.0
IS65-40-250	15	4.17	82	2900	9.05	15	37	254	2.0
	25	6.94	80		10.89		50		2.0
	30	8.33	78		12.02		53		2.5
IS65-40-250A	23.4	6.5	70	2900	9.10	11	49	238	2.0

IS型单级单吸离心泵

IS Series Single-stage End-suction Centrifugal Pump

性能参数表 PERFORMANCE TABLE

型号 Model	流量 Capacity		扬程 Head (m)	转速 Speed (r/min)	功率 Power (kW)		效率 Eff. (%)	叶轮名义直径 Impeller diameter (mm)	汽蚀余量 (NPSH) _r (m)
	(m ³ /h)	(L/s)			轴功率 Shaft	电机功率 Motor power			
IS65-40-250B	21.7	6	60	2900	7.51	11	47	220	2.0
IS65-40-315	15	4.17	127	2900	18.5	30	28	315	2.5
	25	6.94	125		21.3		40		2.5
	30	8.33	123		22.8		44		3.0
IS65-40-315A	23.9	6.6	114	2900	19.41	22	38	301	2.5
IS65-40-315B	22.7	6.3	103	2900	17.19	22	37	286	2.5
IS65-40-315C	21.4	5.9	92	2900	15.20	18.5	35	270	2.5
IS80-65-125	30	8.33	22.5	2900	2.87	5.5	64	137	3.0
	50	13.9	20		3.63		75		3.0
	60	16.7	18		3.98		74		3.5
IS80-65-125A	44.7	12.4	16	2900	2.66	3	73	125	3.0
IS80-65-160	30	8.33	36	2900	4.82	7.5	61	168	2.5
	50	13.9	32		5.97		73		2.5
	60	16.7	29		6.59		72		3.0
IS80-65-160A	46.8	13	28	2900	5.10	5.5	70	157	2.5
IS80-65-160B	43.3	12	24	2900	4.15	5.5	68	146	2.5
IS80-50-200	30	8.33	55	2900	7.87	15	55	202	2.5
	50	13.9	50		9.87		69		2.5
	60	16.7	47		10.8		71		3.0
IS80-50-200A	46.8	13	44	2900	8.37	11	67	190	2.5
IS80-50-200B	43.6	12.1	38	2900	6.83	11	66	176	2.5
IS80-50-250	30	8.33	84	2900	13.2	22	52	252	2.5
	50	13.9	80		17.3		63		2.5
	60	16.7	75		19.2		64		3.0
IS80-50-250A	46.8	13	70	2900	14.87	18.5	60	238	2.5
IS80-50-250B	43.3	13	60	2900	13.18	15	58	218	2.5
IS80-50-315	30	8.33	128	2900	25.5	37	41	315	2.5
	50	13.9	125		31.5		54		2.5
	60	16.7	123		35.3		57		3.0
IS80-50-315A	47.8	13.3	114	2900	29.15	37	51	301	2.5
IS80-50-315B	45.4	12.6	103	2900	25.97	30	49	286	2.5
IS80-50-315C	42.9	11.9	92	2900	22.84	30	47	270	2.5
IS100-80-125	60	16.7	24	2900	5.86	11	67	140	4.0
	100	27.8	20		7.0		78		4.5
	120	33.3	16.5		7.28		74		5.0
IS100-80-125A	89.4	24.8	16	2900	5.19	7.5	75	125	4.5

性能参数表 PERFORMANCE TABLE

型号 Model	流量 Capacity		扬程 Head (m)	转速 Speed (r/min)	功率 Power (kW)		效率 Eff. (%)	叶轮名义直径 Impeller diameter (mm)	汽蚀余量 (NPSH) _r (m)
	(m ³ /h)	(L/s)			轴功率 Shaft	电机功率 Motor power			
IS100-80-160	60	16.7	36	2900	8.42	15	790	170	3.5
	100	27.8	32		11.2		78		4.0
	120	33.3	28		12.2		75		5.0
IS100-80-160A	93.5	26	28	2900	9.52	11	75	159	4.0
IS100-80-160B	86.6	24.1	24	2900	7.77	11	73	147	4.0
IS100-65-200	60	16.7	54	2900	13.6	22	65	203	3.0
	100	27.8	50		17.9		76		3.6
	120	33.3	47		19.9		77		4.8
IS100-65-200A	93.8	26.1	44	2900	15.01	18.5	75	190	3.6
IS100-65-200B	87.2	24.2	38	2900	12.52	15	72	177	3.6
IS100-65-250	60	16.7	87	2900	23.4	37	61	255	3.5
	100	27.8	80		30.3		72		3.8
	120	33.3	74.5		33.3		73		4.8
IS100-65-250A	93.5	26	70	2900	25.49	30	70	239	3.8
IS100-65-250B	86.6	24.1	60	2900	20.85	30	68	221	3.8
IS100-65-315	60	16.7	133	2900	39.6	75	55	315	3.0
	100	27.8	125		51.6		66		3.6
	120	33.3	118		57.5		67		4.2
IS100-65-315A	95.5	26.5	114	2900	46.28	55	64	301	3.6
IS100-65-315B	90.8	25.2	103	2900	41.04	45	62	286	3.6
IS100-65-315C	85.8	23.8	92	2900	35.78	45	60	271	3.6
IS125-100-200	120	33.3	57.5	2900	28.0	45	67	216	4.5
	200	55.5	50		33.6		81		4.5
	240	66.7	44.5		36.4		80		5.0
IS125-100-200A	187	52	44	2900	28.76	37	78	203	4.5
IS125-100-200B	174.4	48.4	38	2900	23.73	30	76	188	4.5
IS125-100-250	120	33.3	87	2900	43.0	75	66	255	3.8
	200	55.6	80		55.9		78		4.2
	240	66.7	72		62.8		75		5.0
IS125-100-250A	187	52	70	2900	46.96	55	76	239	4.2
IS125-100-250B	173.2	48.1	60	2900	38.24	45	74	221	4.2
IS125-100-315	120	33.3	132.5	2900	72.1	110	60	317	4.0
	200	55.6	125		90.8		75		4.5
	240	66.7	120		101.9		77		5.0
IS125-100-315A	191	53.1	114	2900	81.30	90	73	303	4.5
IS125-100-315B	181.5	50.4	103	2900	71.68	90	71	288	4.5

IS型单级单吸离心泵

IS Series Single-stage End-suction Centrifugal Pump

性能参数表 PERFORMANCE TABLE

型号 Model	流量 Capacity		扬程 Head (m)	转速 Speed (r/min)	功率 Power (kW)		效率 Eff. (%)	叶轮名义直径 Impeller diameter (mm)	汽蚀余量 (NPSH)r (m)
	(m ³ /h)	(L/s)			轴功率 Shaft	电机功率 Motor power			
IS125-100-315C	171.6	47.7	92	2900	62.35	75	69	272	4.5
IS50-32-125	3.75	1.04	5.4	1450	0.13	0.55	43	130	2.0
	6.3	1.74	5.0		54		2.0		
	7.5	2.08	4.6		55		2.5		
IS50-32-125A	5.6	1.6	4	1450	0.12	0.55	53	116	2.0
IS50-32-160	3.75	1.04	8.5	1450	0.25	0.55	35	158	2.0
	6.3	1.74	8.0		48		2.0		
	7.5	2.08	7.5		49		2.5		
IS50-32-160A	5.8	1.6	7	1450	0.24	0.55	46	148	2.0
IS50-32-160B	5.4	1.5	6	1450	0.21	0.55	43	137	2.0
IS50-32-200	3.75	1.04	13.1	1450	0.41	0.75	33	198	2.0
	6.3	1.74	12.5		42		2.0		
	7.5	2.08	12		44		2.5		
IS50-32-200A	5.8	1.6	11	1450	0.43	0.55	40	186	2.0
IS50-32-200B	5.4	1.5	9.5	1450	0.37	0.55	38	173	2.0
IS50-32-250	3.75	1.04	20.5	1450	0.91	1.5	23	250	2.0
	6.3	1.74	20		32		2.0		
	7.5	2.08	19.5		35		2.5		
IS50-32-250A	5.8	1.6	17.5	1450	0.92	1.5	30	234	2.0
IS50-32-250B	5.4	1.5	15	1450	0.85	1.1	26	217	2.0
IS65-50-125	7.5	2.08	5.35	1450	0.21	0.55	53	130	2.0
	12.5	3.47	5.0		64		2.0		
	15	4.17	4.7		65		2.5		
IS65-50-125A	11.2	3.1	4	1450	0.20	0.55	62	116	2.0
IS65-50-160	7.5	2.08	8.8	1450	0.36	0.75	50	165	2.0
	12.5	3.47	8.0		60		2.0		
	15	4.17	7.2		60		2.5		
IS65-50-160A	11.7	3.3	7	1450	0.39	0.55	58	154	2.0
IS65-50-160B	10.8	3	6	1450	0.32	0.55	56	143	2.0
IS65-40-200	7.5	2.08	13.2	1450	0.63	1.1	43	200	2.0
	12.5	3.47	12.5		55		2.0		
	15	4.17	11.8		57		2.5		
IS65-40-200A	11.7	3.3	11	1450	0.70	1.1	51	188	2.0
IS65-40-200B	10.8	3	9.5	1450	0.58	0.75	48	175	2.0
IS65-40-250	7.5	2.08	21	1450	1.23	2.2	35	254	2.0
	12.5	3.47	20		46		2.0		
	15	4.17	19.4		48		2.5		

性能参数表 PERFORMANCE TABLE

型号 Model	流量 Capacity		扬程 Head (m)	转速 Speed (r/min)	功率 Power (kW)		效率 Eff. (%)	叶轮名义直径 Impeller diameter (mm)	汽蚀余量 (NPSH) _r (m)
	(m ³ /h)	(L/s)			轴功率 Shaft	电机功率 Motor power			
IS65-40-250A	11.7	3.3	17.5	1450	1.23	1.5	46	238	2.0
IS65-40-250B	10.8	3	15	1450	1.00	1.5	44	220	2.0
IS65-40-315	7.5	2.08	32.3	1450	2.63	4	25	315	2.5
	12.5	3.47	32.0		2.94		37		2.5
	15	4.17	31.7		3.16		41		3.0
IS65-40-315A	11.9	3.3	28.5	1450	2.63	3	35	301	2.5
IS65-40-315B	11.3	3.2	25.8	1450	2.38	3	34	286	2.5
IS65-40-315C	10.7	3	23	1450	2.11	3	32	270	2.5
IS80-65-125	15	4.17	5.6	1450	0.42	0.75	55	137	2.5
	25	6.94	5		0.48		71		2.5
	30	8.33	4.5		0.51		72		3.0
IS80-65-125A	22.4	6.2	4	1450	0.35	0.55	69	125	2.5
IS80-65-160	15	4.17	9	1450	0.37	1.5	55	168	2.5
	25	6.94	8		0.79		69		2.5
	30	8.33	7.2		0.86		68		3.0
IS80-65-160A	23.4	6.5	7	1450	0.68	1.1	66	157	2.5
IS80-65-160B	21.7	6	6	1450	0.55	0.75	64	146	2.5
IS80-50-200	15	4.17	13.2	1450	1.06	2.2	51	202	2.5
	25	6.94	12.5		1.31		65		2.5
	30	8.33	11.8		1.41		67		3.0
IS80-50-200A	23.4	6.5	11	1450	1.10	1.5	64	190	2.5
IS80-50-200B	21.8	6.1	9.5	1450	0.90	1.1	63	176	2.5
IS80-50-250	15	4.17	21	1450	1.75	3	49	252	2.5
	25	6.94	20		2.27		60		2.5
	30	8.33	18.8		2.52		61		3.0
IS80-50-250A	23.4	6.5	17.5	1450	1.96	2.2	57	238	2.5
IS80-50-250B	21.7	6	15	1450	1.60	2.2	55	218	2.5
IS80-50-315	15	4.17	32.5	1450	3.4	5.5	39	315	2.5
	25	6.94	32		4.19		52		2.5
	30	8.33	31.5		4.6		56		3.0
IS80-50-315A	23.9	6.6	28.5	1450	3.76	5.5	49	301	2.5
IS80-50-315B	22.7	6.3	25.8	1450	3.46	4	46	286	2.5
IS80-50-315C	21.4	6	23	1450	3.07	4	44	270	2.5
IS100-80-125	30	8.33	6	1450	0.77	1.5	64	140	2.5
	50	13.9	5		0.91		75		2.5
	60	16.7	4		0.92		71		3.0

IS型单级单吸离心泵

IS Series Single-stage End-suction Centrifugal Pump

性能参数表 PERFORMANCE TABLE

型号 Model	流量 Capacity		扬程 Head (m)	转速 Speed (r/min)	功率 Power (kW)		效率 Eff. (%)	叶轮名义直径 Impeller diameter (mm)	汽蚀余量 (NPSH)r (m)
	(m ³ /h)	(L/s)			轴功率 Shaft	电机功率 Motor power			
IS100-80-125A	44.7	12.4	4	1450	0.68	1.1	72	125	2.5
IS100-80-160	30	8.33	9.2	1450	1.12	2.2	67	170	2.0
	50	13.9	8.0		75		2.5		
	60	16.7	6.8		71		3.5		
IS100-80-160A	46.8	13	7	1450	1.24	1.5	72	159	2.5
IS100-80-160B	43.3	12	6	1450	1.01	1.5	70	147	2.5
IS100-65-200	30	8.33	13.5	1450	1.84	4	60	203	2.0
	50	13.9	12.5		73		2.0		
	60	16.7	11.8		74		2.5		
IS100-65-200A	46.9	13	11	1450	1.95	3	72	190	2.0
IS100-65-200B	43.6	12.1	9.5	1450	1.63	2.2	69	177	2.0
IS100-65-250	30	8.33	21.3	1450	3.16	5.5	55	255	2.0
	50	13.9	20		68		2.0		
	60	16.7	19		70		2.5		
IS100-65-250A	46.8	13	17.5	1450	3.38	4	66	239	2.0
IS100-65-250B	43.3	12	15	1450	2.76	4	64	221	2.0
IS100-65-315	30	8.33	34	1450	5.44	11	51	315	2.0
	50	13.9	32		63		2.0		
	60	16.7	30		61		2.5		
IS100-65-315A	47.7	13.3	28.5	1450	6.09	7.5	61	301	2.0
IS100-65-315B	45.4	12.6	25.8	1450	5.40	7.5	59	286	2.0
IS100-65-315C	42.9	11.9	23	1450	4.71	5.5	57	271	2.0
IS125-100-200	60	16.7	14.5	1450	3.83	7.5	62	216	2.5
	100	27.8	12.5		76		2.5		
	120	33.3	11.0		75		3.0		
IS125-100-200A	93.5	26	11	1450	3.84	5.5	73	203	2.5
IS125-100-200B	87.2	24.2	9.5	1450	3.17	4	71	188	2.5
IS125-100-250	60	16.7	21.5	1450	5.59	11	63	255	2.5
	100	27.8	20		76		2.5		
	120	33.3	18.5		77		3.0		
IS125-100-250A	93.5	26	17.5	1450	6.03	7.5	74	239	2.5
IS125-100-250B	86.6	24.1	15	1450	4.92	7.5	72	221	2.5
IS125-100-315	60	16.7	33.5	1450	9.4	15	58	317	2.5
	100	27.8	32		73		2.5		
	120	33.3	30.5		74		3.0		
IS125-100-315A	95.5	26.5	28.5	1450	10.43	15	71	303	2.5

性能参数表 PERFORMANCE TABLE

型号 Model	流量 Capacity		扬程 Head (m)	转速 Speed (r/min)	功率 Power (kW)		效率 Eff. (%)	叶轮名义直径 Impeller diameter (mm)	汽蚀余量 (NPSH) _r (m)
	(m ³ /h)	(L/s)			轴功率 Shaft	电机功率 Motor power			
IS125-100-315B	90.8	25.2	25.8	1450	9.37	11	68	288	2.5
IS125-100-315C	85.8	23.8	23	1450	8.13	11	66	272	2.5
IS125-100-400	60	16.7	52	1450	16.1	30	53	395	2.5
	100	27.8	50		21.0		65		3.0
	120	33.3	48.5		23.6		67		3.0
IS125-100-400A	93.5	26	44	1450	17.8	22	63	371	3.0
IS125-100-400B	86.6	24.1	38	1450	14.96	18.5	63	345	3.0
IS150-125-250	120	33.3	22.5	1450	10.4	18.5	71	260	3.0
	200	55.6	20		13.5		81		3.0
	240	66.7	17.5		14.7		78		3.5
IS150-125-250A	187	52	17.5	1450	11.44	15	78	243	3.0
IS150-125-250B	173	48	15	1450	9.29	11	76	225	3.0
IS150-125-315	120	33.3	34	1450	15.9	30	70	325	2.5
	200	55.6	32		22.1		79		2.5
	240	66.7	29		23.7		80		3.0
IS150-125-315A	187	52	28	1450	18.78	22	76	304	2.5
IS150-125-315B	173	48	24	1450	15.47	18.5	73	282	2.5
IS150-125-400	120	33.3	53	1450	27.9	45	62	400	2.0
	200	55.6	50		36.3		75		2.8
	240	66.7	46		40.6		74		3.5
IS150-125-400A	187	52	44	1450	30.73	37	73	375	2.8
IS150-125-400B	173	48	38	1450	25.19	30	71	348	2.8
IS200-150-250	240	66.7	22.6	1450	21.1	37	70	375	3.6
	400	111.1	20		26.6		82		4.6
	460	127.8	17.2		27.3		79		4.9
IS200-150-250A	374	104	17.5	1450	22.30	30	80	257	4.6
IS200-150-250B	346	96	15	1450	18.10	22	78	238	4.6
IS200-150-315	240	66.7	37	1450	34.6	55	70	348	3.0
	400	111.1	32		42.5		82		3.5
	460	127.8	28.5		44.6		80		4.0
IS200-150-315A	374	104	28	1450	35.69	45	80	326	3.5
IS200-150-315B	346	96	24	1450	28.96	37	78	301	3.5
IS200-150-400	240	66.7	55	1450	48.6	90	74	395	3.0
	400	111.1	50		67.2		81		3.8
	460	127.8	45		74.2		76		4.5
IS200-150-400A	374	104	44	1450	56.79	75	79	371	3.8
IS200-150-400B	346	96	38	1450	46.45	55	77	342	3.8

IS型单级单吸离心泵

IS Series Single-stage End-suction Centrifugal Pump

泵脚座尺寸图表 PUMP BASE DIMENSION DRAWING AND TABLE

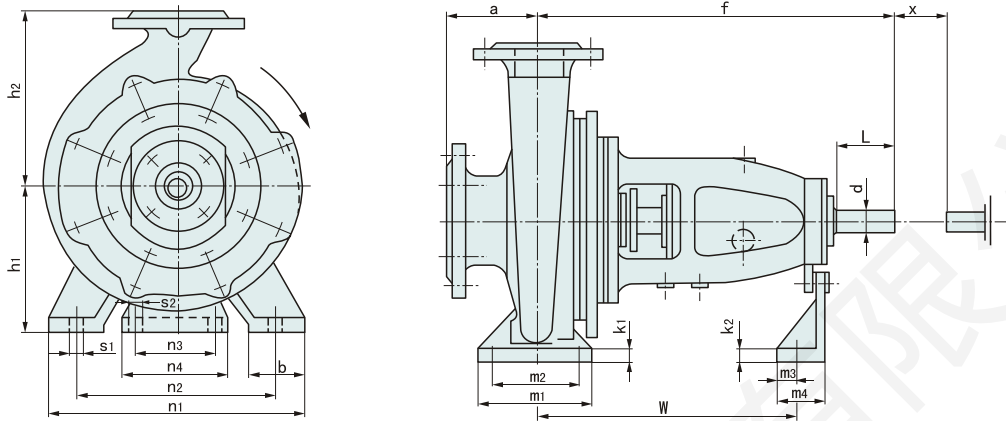

型号 Model	泵 Pump					泵脚座 Pump seat										W	螺栓孔 Bolt hole		轴端 Shaft end		间隔 Clearance
	a	f	h1	h2	b	m1	m2	m3	m4	n1	n2	n3	n4	k1	k2		s1	s2	d	L	
IS50-32-125	80	385	112	140	50	100	70	19	60	190	140	110	145	14	10	288	M12	M12	24	50	100
IS50-32-160	80	385	132	160	50	100	70	19	60	240	190	110	145	14	10	285	M12	M12	24	50	100
IS50-32-200	100	385	160	180	50	100	70	19	60	240	190	110	145	16	10	285	M12	M12	24	50	100
IS50-32-250	80	500	180	225	65	129	95	25	65	320	250	110	145	20	14	370	M12	M12	32	80	100
IS65-50-125	80	385	112	140	50	100	70	19	60	210	160	110	145	14	10	285	M12	M12	24	50	100
IS65-50-160	100	385	132	160	50	100	70	19	60	240	190	110	145	16	10	285	M12	M12	24	50	100
IS65-40-200	100	385	160	180	50	100	70	19	60	265	212	110	145	16	10	285	M12	M12	24	50	100
IS65-40-250	125	500	180	225	65	125	95	25	65	320	250	110	145	20	14	370	M12	M12	32	80	100
IS65-40-315	100	500	200	250	65	125	95	25	65	345	280	110	145	20	14	370	M12	M12	32	80	100
IS80-65-125	100	385	132	160	50	100	70	19	60	240	190	110	145	16	10	285	M12	M12	24	50	100
IS80-65-160	100	385	160	180	50	100	70	19	60	265	212	110	145	16	10	285	M12	M12	24	50	100
IS80-50-200	125	385	160	200	50	100	70	19	60	265	212	110	145	20	10	285	M12	M12	24	50	100
IS80-50-250	125	500	180	225	65	125	95	25	65	320	250	110	145	20	14	370	M12	M12	32	80	100
IS80-50-315	100	500	225	280	65	125	95	25	65	345	280	110	145	20	14	370	M12	M12	32	80	100
IS100-80-125	100	385	160	180	65	125	95	19	60	280	212	110	145	16	10	285	M12	M12	24	50	100
IS100-80-160	100	500	160	200	65	125	95	24	60	280	212	110	145	20	10	370	M12	M12	32	80	100
IS100-65-200	125	500	180	225	65	125	95	25	65	320	250	110	145	20	14	370	M12	M12	32	80	140
IS100-65-250	125	500	200	250	80	160	120	25	65	360	280	110	145	20	14	370	M16	M12	32	80	140
IS100-65-315	125	530	225	280	80	160	120	28	65	400	315	110	145	25	14	370	M16	M12	42	110	140
IS125-100-200	140	500	200	280	80	160	120	25	65	360	280	110	145	20	14	370	M16	M12	32	80	140
IS125-100-250	140	530	225	280	80	160	120	28	65	400	315	110	145	20	14	370	M16	M12	42	110	140
IS125-100-315	140	530	250	315	80	160	120	28	65	400	315	110	145	25	14	370	M16	M12	42	110	140
IS125-100-400	140	530	280	355	100	200	150	28	65	500	400	110	145	25	14	370	M20	M12	42	110	140
IS150-125-250	140	530	250	355	80	160	120	28	65	400	315	110	145	25	14	370	M16	M12	42	110	140
IS150-125-315	140	530	280	355	100	200	150	28	65	500	400	110	145	25	14	370	M20	M12	42	110	140
IS150-125-400	140	530	315	400	100	200	150	28	65	500	400	110	145	25	14	370	M20	M12	42	110	140
IS200-150-250	160	530	280	375	100	200	150	28	65	500	400	110	145	25	14	370	M20	M18	42	110	180
IS200-150-315	160	670	315	400	100	200	150	38	80	550	450	140	200	30	30	500	M20	M16	48	110	180
IS200-150-400	160	670	315	450	100	200	150	38	80	550	450	140	200	30	30	500	M20	M16	48	110	180

注：X是向驱动一侧退出转子所必需的间隔。

Remarks: X is the necessary clearance when the rotor quits one driving side.

进出口法兰尺寸图 IN-OUTLET FLANGE DIMENSION DRAWING

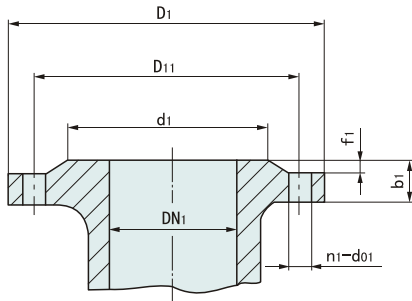
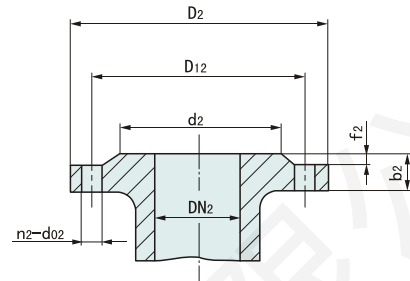
吸入口法兰
Inlet flange吐出口法兰
Outlet flange

进出口法兰尺寸表 IN-OUTLET FLANGE DIMENSION TABLE

型号 Model	吸入口法兰尺寸 Inlet flange dimension							吐出口法兰尺寸 Outlet flange dimension						
	DN ₁	D ₁	D ₁₁	d ₁	b ₁	f ₁	n ₁ -d ₀₁	DN ₂	D ₂	d ₁₂	d ₂	b ₂	f ₂	n ₂ -d ₀₂
IS50-32-125	50	165	125	105	20	3	4-17.5	32	140	100	78	18	2	4-17.5
IS50-32-160	50	165	125	105	20	3	4-17.5	32	140	100	78	18	2	4-17.5
IS50-32-200	50	165	125	105	20	3	4-17.5	32	140	100	78	18	2	4-17.5
IS50-32-250	50	165	125	105	20	3	4-17.5	32	140	100	78	18	2	4-17.5
IS65-50-125	65	185	145	122	20	3	4-17.5	50	165	125	102	20	3	4-17.5
IS65-50-160	65	185	145	122	20	3	4-17.5	50	165	125	102	20	3	4-17.5
IS65-40-200	65	185	145	122	20	3	4-17.5	40	150	110	88	18	3	4-17.5
IS65-40-250	65	185	145	122	20	3	4-17.5	40	150	110	88	18	3	4-17.5
IS65-40-315	65	185	145	122	20	3	8-17.5	40	150	110	88	18	3	4-17.5
IS80-65-125	80	200	160	133	22	3	8-17.5	65	185	145	122	20	3	4-17.5
IS80-65-160	80	200	160	133	22	3	8-17.5	65	185	145	122	20	3	4-17.5
IS80-50-200	80	200	160	133	24	3	8-17.5	50	165	125	102	20	3	4-17.5
IS80-50-250	80	200	160	133	24	3	8-17.5	50	165	125	102	20	3	4-17.5
IS80-50-315	80	200	160	133	24	3	8-17.5	50	165	125	102	20	3	4-17.5
IS100-80-125	100	220	180	158	24	3	8-17.5	80	200	160	133	22	3	8-17.5
IS100-80-160	100	220	180	158	24	3	8-17.5	80	200	160	133	22	3	8-17.5
IS100-65-200	100	220	180	158	26	3	8-17.5	65	185	145	122	20	3	4-17.5
IS100-65-250	100	220	180	158	26	3	8-17.5	65	185	145	122	20	3	4-17.5
IS100-65-315	100	225	180	158	26	3	8-17.5	65	185	145	122	20	3	4-17.5
IS125-100-200	125	250	210	184	26	3	8-17.5	100	220	180	158	24	3	8-17.5
IS125-100-250	125	250	210	184	26	3	8-17.5	100	220	180	158	24	3	8-17.5
IS125-100-315	125	250	210	184	26	3	8-17.5	100	220	180	158	24	3	8-17.5
IS125-100-400	125	250	210	184	26	3	8-17.5	100	220	180	158	24	3	8-17.5
IS150-125-250	150	285	240	212	26	3	8-22	125	250	210	184	26	3	8-17.5
IS150-125-315	150	285	240	212	26	3	8-22	125	250	210	184	26	3	8-17.5
IS150-125-400	150	285	240	212	26	3	8-22	125	250	210	184	26	3	8-17.5
IS200-150-250	200	340	295	268	30	3	12-22	150	285	240	212	26	3	8-22
IS200-150-315	200	340	295	268	30	3	12-22	150	285	240	212	26	3	8-22
IS200-150-400	200	340	295	268	30	3	12-22	150	285	240	212	26	3	8-22

IS型单级单吸离心泵

IS Series Single-stage End-suction Centrifugal Pump

外形及安装尺寸图 OUT-FORM AND INSTALLATION DIMENSION DRAWING

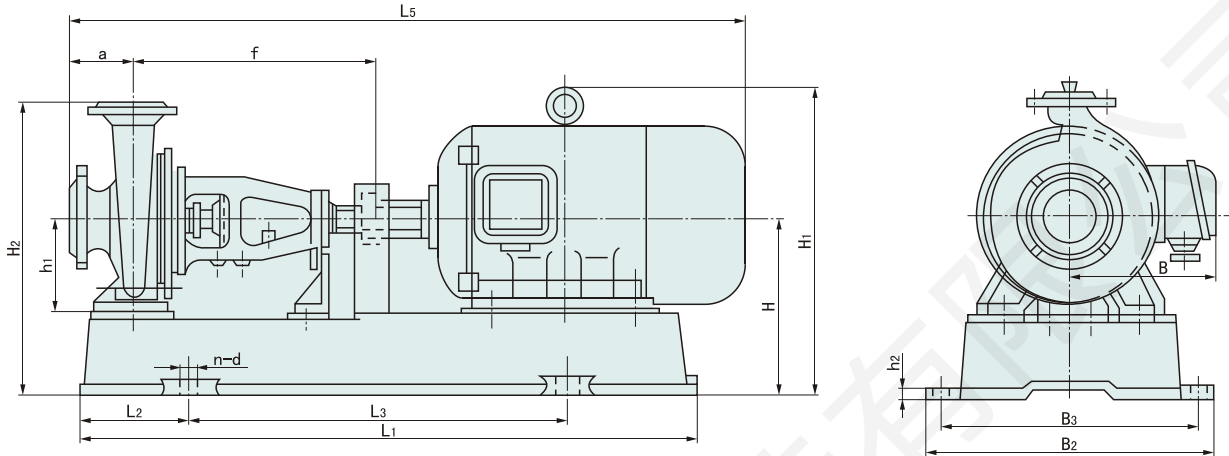

外形及安装尺寸表 OUT-FORM AND INSTALLATION DIMENSION TABLE

型号 Model	机座号/功率 Seat No./power (kw)	外形及安装尺寸 Out-form and installation dimension															
		L1	L2	L3	L4	a	f	L5	B1	B2	B3	h1	h2	H	H1	H2	n-d
IS50-32-125	80-4/0.55	820	150	540	285	80	885	850	150	360	320	112	25	187	327	277	4-φ18.5
	80-2/1.1	820	150	540	285	80	885	850	150	360	320	112	25	187	327	277	4-φ18.5
	90S-2/1.5	820	150	540	310	80	885	875	155	360	320	112	25	187	327	277	4-φ18.5
	90L-2/2.2	920	170	600	335	80	885	900	155	390	350	112	25	187	327	287	4-φ18.5
IS50-32-160	80-4/0.55	820	150	540	285	80	385	850	150	360	320	132	25	207	367	297	4-φ18.5
	90S-2/1.5	820	150	540	310	80	385	875	155	360	320	132	25	207	367	307	4-φ18.5
	90L-2/2.2	920	170	600	335	80	385	900	155	360	320	132	25	207	367	307	4-φ18.5
	100L-2/3.2	920	170	600	380	80	385	945	180	390	350	132	25	207	367	352	4-φ18.5
IS50-32-200	80-4/0.75	820	150	540	285	80	385	850	150	360	320	160	25	235	415	325	4-φ18.5
	100L-2/3	920	170	600	380	80	385	945	180	390	350	160	25	235	415	380	4-φ18.5
	112M-2/4	920	170	600	400	80	385	965	190	390	350	160	25	235	415	388	4-φ18.5
	132S-2/5.5	1020	190	660	475	80	385	1040	210	450	400	160	30	235	415	418	4-φ24
IS50-32-250	90S-4/1.1	1020	190	660	310	100	500	1010	155	450	400	180	30	255	480	355	4-φ24
	90L-4/1.5	1020	190	660	335	100	500	1035	155	450	400	180	30	255	480	355	4-φ24
	132S-2/7.5	1160	210	740	475	100	500	1175	210	490	440	180	30	270	495	453	4-φ24
	160M-2/11	1290	225	840	600	100	500	1300	255	540	490	180	30	290	515	515	4-φ24
IS65-50-125	88-4/0.55	820	150	510	285	80	385	850	150	360	320	112	25	187	327	277	4-φ18.5
	90S-2/1.5	820	150	540	310	80	385	875	155	360	320	112	25	187	327	287	4-φ18.5
	90L-2/2.2	920	170	600	335	80	385	900	155	390	350	112	25	187	327	287	4-φ18.5
	100L-2/3	920	170	600	380	80	385	945	180	390	350	112	25	187	327	332	4-φ18.5

外形及安装尺寸表 OUT-FORM AND INSTALLATION DIMENSION TABLE

型号 Model	机座号/功率 Seat No./power (kw)	外形及安装尺寸 Out-form and installation dimension															
		L ₁	L ₂	L ₃	L ₄	a	f	L ₅	B ₁	B ₂	B ₃	h ₁	h ₂	H	H ₁	H ₂	n-d
IS65-50-160	88-4/0.75	820	150	540	285	80	385	850	50	360	320	132	25	207	367	297	4-φ18.5
	100L-2/3	920	170	600	380	80	385	945	180	390	350	132	25	207	367	352	4-φ18.5
	112M-2/4	920	170	600	400	80	385	965	190	390	350	132	25	207	367	360	4-φ18.5
	132S-2/5.5	1020	190	660	475	80	385	1040	210	450	400	132	30	207	367	390	4-φ24
IS65-40-200	80-4/0.75	920	170	600	285	100	385	870	150	390	350	160	25	235	415	325	4-φ18.5
	90S-4/1.1	920	170	600	310	100	385	895	155	390	350	160	25	235	415	335	4-φ18.5
	112M-2/4	920	170	600	400	100	385	985	190	390	350	160	25	235	415	388	4-φ18.5
	132S-2/7.5	1020	190	660	475	100	385	1060	210	450	400	160	30	235	415	418	4-φ24
IS65-40-250	90S-4/1.1	1020	190	660	310	100	500	1010	155	450	400	180	30	255	480	355	4-φ24
	90L-4/1.5	1020	190	660	335	100	500	1035	155	450	400	180	30	255	480	365	4-φ24
	100L-4/2.2	1020	190	660	380	100	500	1080	188	450	400	180	30	255	480	400	4-φ24
	132S-2/7.5	1160	210	740	475	100	500	1175	210	490	440	180	30	270	495	453	4-φ24
	160M-2/15	1290	225	840	600	100	500	1300	255	540	490	180	30	290	515	515	4-φ24
IS65-40-315	100L-4/3	1140	210	740	380	125	500	1105	180	490	440	200	30	290	540	435	4-φ24
	112-4/4	1140	210	740	400	125	500	1125	190	490	440	200	30	290	540	443	4-φ24
	160L-2/18.5	1290	225	840	645	125	500	1370	255	540	490	200	30	310	560	535	4-φ24
	180M-2/22	1290	225	840	670	125	500	1395	285	540	490	200	30	310	560	560	4-φ24
	200L-2/30	1420	250	940	775	125	500	1500	310	610	550	200	40	330	580	605	4-φ28
IS80-65-125	80-4/0.75	820	150	540	285	100	385	870	150	360	320	132	25	207	367	297	4-φ18.5
	100L-2/3	920	170	600	385	100	385	965	180	390	350	132	25	207	367	352	4-φ18.5
	112M-2/4	920	170	600	400	100	385	985	190	390	350	132	25	207	367	360	4-φ18.5
	132S-2/5.5	1020	190	660	475	100	385	1060	210	450	400	132	35	207	367	390	4-φ24
IS80-65-160	80-4/0.75	920	170	600	285	100	385	870	150	390	350	160	25	235	415	325	4-φ18.5
	90S-4/1.1	920	170	600	310	100	385	895	155	390	350	160	25	235	415	335	4-φ18.5
	90L-4/1.5	920	170	600	335	100	385	920	155	390	350	160	25	235	415	335	4-φ18.5
	112M-2/4	920	170	600	400	100	385	985	190	390	350	160	25	235	415	388	4-φ18.5
	132S-2/7.5	1020	190	660	475	100	385	1060	210	450	400	160	30	235	415	418	4-φ24
IS80-50-200	90S-4/1.1	920	170	600	310	100	385	895	155	390	350	160	25	235	435	335	4-φ18.5
	90L-4/1.5	920	170	600	335	100	385	920	155	390	350	160	25	235	435	335	4-φ18.5
	100L-4/2.2	920	170	600	380	100	385	965	180	390	350	160	25	235	435	380	4-φ18.5
	132S-2/7.5	1020	190	660	475	100	385	1060	210	450	400	160	30	235	435	398	4-φ24
	160M-2/15	1140	210	740	600	100	385	1185	255	490	440	160	30	250	450	475	4-φ24
IS80-50-250	100L-4/3	1020	190	660	380	125	500	1105	180	450	400	180	30	255	480	400	4-φ24
	160M-2/15	1290	225	840	600	125	500	1325	255	540	490	180	30	290	515	515	4-φ24
	160L-2/18.5	1290	225	840	645	125	500	1370	255	540	490	180	30	290	515	515	4-φ24
	180M-2/22	1290	225	840	670	125	500	1395	285	540	490	180	30	290	515	540	4-φ24

IS型单级单吸离心泵

IS Series Single-stage End-suction Centrifugal Pump

外形及安装尺寸表 OUT-FORM AND INSTALLATION DIMENSION TABLE

型号 Model	机座号/功率 Seat No./power (kw)	外形及安装尺寸 Out-form and installation dimension															
		L ₁	L ₂	L ₃	L ₄	a	f	L ₅	B ₁	B ₂	B ₃	h ₁	h ₂	H	H ₁	H ₂	n-d
IS80-50-315	112M-4/4	1140	210	740	400	125	500	1125	190	490	440	225	30	315	595	468	4-φ24
	132S-4/5.5	1160	210	740	475	125	500	1200	210	490	440	225	30	315	595	498	4-φ24
	180M-2/22	1290	225	840	670	125	500	1395	285	540	490	225	30	335	615	585	4-φ24
	200L-2/37	1420	250	940	775	125	500	1500	310	610	550	225	40	355	635	630	4-φ28
IS100-80-125	80-4/0.75	920	170	600	285	100	385	870	150	390	350	160	25	235	415	325	4-φ18.5
	90S-4/1.1	920	170	600	310	100	385	895	155	390	350	160	25	235	415	335	4-φ18.5
	90L-4/1.5	920	170	600	335	100	385	920	155	390	350	160	25	235	415	335	4-φ18.5
	132S-2/7.5	1020	190	660	475	100	385	1060	210	450	400	160	30	235	415	418	4-φ24
	160M-2/11	1140	210	740	600	100	385	1185	255	490	440	160	30	250	430	475	4-φ24
IS100-80-160	90L-4/1.5	1020	190	660	335	100	500	1035	155	450	400	160	30	235	435	335	4-φ24
	100L-4/2.2	1020	190	660	380	100	500	1080	180	450	400	160	30	235	435	380	4-φ24
	160M-2/15	1290	225	840	600	100	500	1300	255	540	490	160	30	270	470	495	4-φ24
IS100-65-200	100L-4/3	1140	210	740	380	100	500	1120	180	490	440	180	30	270	495	415	4-φ24
	112M-4/4	1140	210	740	400	100	500	1140	190	490	440	180	30	270	495	423	4-φ24
	160M-2/15	1290	225	840	600	100	500	1340	255	540	490	180	30	290	495	495	4-φ24
	160L-2/18.5	1290	225	840	645	100	500	1385	255	540	490	180	30	290	495	495	4-φ24
	180M-2/22	1290	225	840	670	100	500	1410	285	540	490	180	30	290	495	520	4-φ24
IS100-65-250	100L-4/3	1140	210	740	380	125	500	1145	180	490	400	200	30	290	540	435	4-φ24
	112M-4/4	1140	210	740	400	125	500	1165	190	490	400	200	30	290	540	443	4-φ28
	132S-4/5.5	1160	210	740	475	125	500	1240	210	490	400	200	30	290	540	473	4-φ24
	180M-2/22	1290	225	840	670	125	500	1435	285	540	490	200	30	310	560	560	4-φ24
	200L-2/37	1420	250	940	775	125	500	1540	310	610	550	200	40	330	580	605	4-φ28
IS100-65-315	132S-4/5.5	1270	225	840	475	125	530	1270	210	540	490	225	30	335	615	518	4-φ24
	132M-4/7.5	1270	225	840	515	125	530	1310	210	540	490	225	30	335	615	518	4-φ24
	160M-4/11	1270	225	840	600	125	530	1395	255	540	490	225	30	335	615	560	4-φ24
	200-2/37	1420	250	940	775	125	530	1575	315	610	550	225	40	355	635	630	4-φ28
	225M-2/45	1620	290	1060	815	125	530	1610	345	660	600	225	40	375	655	580	4-φ28
	250M-2/55	1620	290	1060	930	125	530	1725	385	660	600	225	40	375	655	700	4-φ28
	280S-2/75	1820	320	1200	1000	125	530	1795	410	730	670	225	40	375	655	735	4-φ28
IS125-100-200	112M-4/4	1140	210	740	400	125	500	1165	190	490	440	200	30	290	570	443	4-φ24
	132S-4/5.5	1160	210	740	475	125	500	1240	210	490	440	200	30	290	570	473	4-φ24
	132M-4/7.5	1160	210	740	515	125	500	1280	210	490	440	200	30	290	570	473	4-φ24
	180M-2/22	1290	225	840	670	125	500	1430	285	540	490	200	30	310	590	560	4-φ24
	200L-2/37	1420	250	940	775	125	500	1510	310	610	550	200	40	330	610	605	4-φ28
	225M-2/45	1420	250	940	815	125	500	1580	345	610	550	200	40	330	610	635	4-φ28

外形及安装尺寸表 OUT-FORM AND INSTALLATION DIMENSION TABLE

型号 Model	机座号/功率 Seat No./power (kw)	外形及安装尺寸 Out-form and installation dimension															
		L ₁	L ₂	L ₃	L ₄	a	f	L ₅	B ₁	B ₂	B ₃	h ₁	h ₂	H	H ₁	H ₂	n-d
IS125-100-250	132S-4/5.5	1270	225	840	475	140	530	1285	210	540	490	225	30	335	615	518	4-φ24
	132M-4/7.5	1270	225	840	515	140	530	1325	210	540	490	225	30	335	615	518	4-φ24
	160M-4/11	1270	225	840	600	140	530	1410	255	540	490	225	30	335	615	560	4-φ24
	200L-2/37	1420	250	940	775	140	530	1585	310	610	550	225	40	355	635	630	4-φ28
	225M-2/45	1620	290	1060	815	140	530	1625	345	660	600	225	40	375	655	680	4-φ28
	250M-2/55	1620	290	1060	930	140	530	1740	385	660	600	225	40	375	655	700	4-φ28
	280S-2/75	1820	320	1200	1000	140	530	1810	410	730	670	225	40	375	655	735	4-φ28
IS125-100-315	160M-4/11	1270	225	840	600	140	530	1410	225	540	490	250	30	360	675	585	4-φ24
	160L-4/15	1420	250	940	645	140	530	1455	225	610	550	250	40	380	695	605	4-φ28
	280S-2/75	1820	320	1200	1000	140	530	1810	410	730	670	250	40	400	715	760	4-φ28
	280M-2/90	1820	320	1200	1050	140	530	1860	410	730	670	250	40	400	715	760	4-φ28
	315S-2/110	1820	320	1200	1190	140	530	2000	460	800	740	250	40	400	715	845	4-φ28
IS125-100-400	160L-4/15	1620	290	1060	645	140	530	1455	255	660	600	280	40	430	785	655	4-φ28
	180M-4/18.5	1620	290	1060	670	140	530	1480	285	660	600	280	40	430	785	680	4-φ28
	180L-4/22	1620	290	1060	710	140	530	1520	285	660	600	280	40	430	785	680	4-φ28
	200L-4/30	1620	290	1060	775	140	530	1585	310	660	600	280	40	430	785	705	4-φ28
IS150-125-250	160L-4/11	1270	225	840	600	140	530	1410	255	540	490	250	30	360	715	585	4-φ24
	160L-4/15	1420	250	940	645	140	530	1455	255	610	550	250	40	380	735	605	4-φ28
	180M-4/18.5	1420	250	940	610	140	530	1480	282	610	550	250	40	380	735	630	4-φ28
IS150-125-315	180M-4/18.5	1620	290	1060	670	140	530	1480	285	660	600	280	40	430	785	680	4-φ28
	180L-4/22	1620	290	1060	710	140	530	1520	285	660	600	280	40	430	785	680	4-φ28
	200L-4/30	1620	290	1060	775	140	530	1585	310	660	600	280	40	430	785	705	4-φ28
IS150-125-400	200L-4/30	1620	290	1060	775	140	530	1585	310	660	600	315	40	465	865	740	4-φ28
	225S-4/37	1620	290	1060	820	140	530	1630	345	660	600	315	40	465	865	770	4-φ28
	225M-4/45	1620	290	1060	845	140	530	1655	345	660	600	315	40	465	865	770	4-φ28
IS200-150-250	180L-4/22	1620	290	1060	710	160	670	1580	285	660	600	280	40	430	805	680	4-φ28
	200L-4/30	1620	290	1060	775	160	670	1645	310	660	600	280	40	430	805	705	4-φ28
	225S-4/37	1620	290	1060	820	160	670	1690	345	660	600	280	40	430	805	735	4-φ28
IS200-150-315	200L-4/30	1820	320	1200	775	160	670	1785	310	730	670	315	40	465	865	740	4-φ28
	225S-4/37	1820	320	1200	820	160	670	1830	345	730	670	315	40	465	865	770	4-φ28
	225M-4/45	1820	320	1200	845	160	670	1855	345	730	670	315	40	465	865	770	4-φ28
	250M-4/55	1820	320	1200	930	160	670	1940	385	730	670	315	40	465	865	790	4-φ28
IS200-150-400	225M-4/55	1820	320	1200	845	160	670	1855	345	730	670	315	40	465	915	770	4-φ28
	250M-4/55	1820	320	1200	930	160	670	1940	385	730	670	315	40	465	915	790	4-φ28
	230S-4/75	1820	320	1200	1000	160	670	2010	410	730	670	315	40	465	915	825	4-φ28
	280M-4/90	1840	320	1200	1050	160	670	2060	410	730	670	315	40	465	915	825	4-φ28

水泵装配与拆卸 PUMP ASSEMBLY AND DISASSEMBLY

泵在装配前应首先检查零件有无影响装配的缺陷，并擦洗干净，方可进行装配。

1、预先可将各处的连接螺栓、丝堵等分别拧紧在相应的零件上。

2、预先可将O形密封圈、纸垫、毛毡等分别放置在相应的零件上。

3、预先可将密封环和填料、填料环、填料压盖等依次装到泵盖内。

4、将滚动轴承装在轴上，然后装到悬架内，再合了压盖，压紧滚动轴承，并往轴上套上连接螺栓。

5、将轴套装到轴上，再将泵盖装到悬架上，然后再将叶轮、止动垫圈、叶轮螺母等装上并拧紧，最后将上述组件装到泵体内，并拧紧泵体及泵盖上的连接螺栓。

在上述装配过程中，一些小件如平键、挡油盘、挡水圈轴套内O形密封圈等容易遗漏或装错顺序，应特别注意。

泵拆卸顺序基本上可按装配顺序的反向进行。

水泵安装 PUMP INSTALLATION

泵安装得好坏对泵的运行和寿命有重要影响，所以安装和校正必须仔细进行。

一、安装和校正

1、清除底座上的油腻和污垢，把底座放在地基上。

2、用水平仪检查底座的水平度，允许用楔铁找平。

3、用水泥浇灌底座和地脚螺栓孔眼。

4、水泥干涸后应检查底座和地脚螺栓孔眼是否松动，合适后拧紧地脚螺栓，重新检查水平度。

5、清理底座的支持平面、水泵脚及电机脚的平面，并把水泵和电机安装到底座上去。

6、联轴器之间应保持一定的间隙，检查水泵轴与电机轴中心线是否一致，可用薄垫片调整使其同心。

测量联轴器的外圆上下、左右的差别不得超过0.1mm，两联轴器端面间隙一周上最大和最小的间隙差别不得超过0.3mm。

Before assembly, first check if there is any defect with the parts affecting the assembly and clean them.

1. Screw in the connecting bolts, screw corks on the corresponding parts in advance.

2. Place the O-seal rings, paper pads, felts etc. on the corresponding parts in advance.

3. Put the sealing, packing, packing ring, packing gland etc. in turn into the pump cover.

4. Mount the rolling bearing on the shaft, then mount it into the suspended stand, put on the gland to press the rolling bearing tightly and put the connecting bolt on the shaft.

5. Mount the muff on the shaft, then mount the pump cover on the suspended stand, mount the impeller, thrust cushion, impeller nut etc. on and tighten them, Finally mount the assembly into the pump casing and tighten the connecting bolts on both pump casing and cover.

During the above assembly process, special attention has to be paid to some small parts, such as flat keys, oil baffle disks, the O-seal rings inside of the muff of water baffle, which are easily missed or mounted in a wrong order.

Carry out the reversed order to disassemble the pump.

The installation quality results in an important factor to the pump's movement and duration, therefore installation and correction must be carefully carried out.

I. Installation and correction

1. Clear up grease and filth on the foundation and then place it on the ground.

2. Check the foundation levelness with a leveler and it is allowed to use a wedge iron for leveling.

3. Pour cement into the foundation and foot bolt holes.

4. After the cement is dried, check if both foundation and foot bolt holes are loose, then properly tighten the foot bolts and recheck the levelness.

5. Clean up the foundation's support plane, the planes of pump and motor feet and mount both pump and motor on the foundation.

6. Keep a certain space between the clutches, check if the central lines of both pump and motor shafts are identical and, if not, use a thin pad to adjust it.

The difference between the upper and lower, right and left of the outer circle of the clutch has not to be over 0.1mm, the difference between the maximum and minimum spaces on one periphery of the two clutches' end-face spaces has not to be over 0.3mm.

二、安装说明

- 1、泵的安装高度，管路的长度、直径、流速应符合计算，力求减少不必要的损失。
- 2、长距离输送时应取较大管径。泵的管路应有自己的支架，不允许管路的重量加在泵上，避免把泵压坏。
- 3、排出管路如装逆止阀应装在闸阀的外面。

II. Installation

1. Have the pump's installation height, the pipeline length and diameter and the flowrate comply with the calculations and try best to reduce unnecessary loss.
2. Use a bigger pipeline diameter for a distance transportation. The pump pipeline should have a stand of its own and do not let the pipeline weight upon the pump to avoid it from pressed damage.
3. Mount the check valve outside of the gate valve on the drain-out pipeline if required to mount it.

水泵启动、停止与运转 PUMP START, STOP AND RUNNING

一、启动

- 1、应在机泵联接前确定电动机的旋转方向是否正确，泵的转动是否灵活。
- 2、关闭吐出管路上的闸阀。
- 3、向泵内灌满水或用真空泵引水。
- 4、接通电源，当泵达到正常转速后，再逐渐打开吐出管路上的闸阀。并调节到所需要的工况。在吐出管上的闸阀关闭的情况下，泵连续工作的时间不能超过3分钟。

I. Start

1. Before linking both pump and motor, make sure the motor moves in the correct direction and the pump moves flexibly.
2. Close the gate valve on the vomit pipeline.
3. Prime water into the pump fully or use a vacuum pump to lead water.
4. Turn on the power. When the pump reaches the normal moving speed, gradually open the gate valve on the vomit pipeline and adjust it to the desired working conditions. The pump is not allowed to continually work over 3 minutes with the gate valve closed.

二、停止

- 1、逐渐关闭吐出管路上的闸阀，切断电源。
- 2、如环境温度低于0℃，应将泵内水放出，以免冻裂。
- 3、如长期停止使用，应将泵拆卸清洗上油，包装保管。

II. Stop

1. Gradually close the gate valve on the vomit pipeline and cut off the power.
2. Drain out the water inside of the pump to prevent it from getting cracked due to freezing when the ambient temperature is below 0℃.
3. In case of a long time stop, disassemble the pump, clean and lubricate it, the pack and store it.

三、运转

- 1、在开车及运转过程中，必须注意观察仪表读数，轴承是否发热，填料是否漏水及泵的振动和杂音等是否正常，如果发现异常情况，应及时处理。
- 2、轴承温度最高不大于80℃，轴承温度不得超过周围温度40℃。
- 3、填料正常，漏水应该是少量均匀的。
- 4、轴承油位应保持在正常位置上，不能过高或过低，过低时应及时补充润滑油。
- 5、如密封环与叶轮配合部位的间隙磨损过大应更换新的密封环。

III. RUNNING

1. During start and running, pay attention to the meter's reading, to the bearing to see if it is heated, to the packing to see if it leaks, to both vibration and noise of the pump to see if they are normal and take on-time process if not.
2. For the bearing temperature, the maximum of it should not be over 80℃ and it should not be over the ambient one by 40℃.
3. The normal leak from the packing should be a little and even.
4. Keep the bearing's oil level at the normal position, without being too high or low, and supplement the lubricating oil on time in case of being too low.
5. Replace the seal ring when the space between the impeller and it becomes bigger due to wear.

故障原因及排除方法 FAILURES CAUSES AND TROUBLESHOOTING

故障现象 Failure	可能产生的原因 Possible causes	排除方法 Troubleshooting
1、水泵不吸水，压力表及真空表的指针剧烈跳动 The pump does not suck water, the pointers of both pressure gauge and vacuum meter jump severely	a、注入水泵的水不够 The water primed into the pump is insufficient b、进水管与仪表漏气 Both water-in pipe and meter leak	a、再往水泵内注水 Prime more water into it b、拧紧堵塞漏气处 Tighten or block up the leaking place
2、水泵不吸水，真空表已显示高度真空 The pump does not suck water, but a high vacuum is shown on the vacuum meter	a、底阀没有打开或已堵塞 The foot valve is not opened or blocked up b、吸水管阻力太大 Too big resistance with the water suction pipe c、吸水高度太高 Too high water suction height	a、校平或更换底阀 Level or replace the foot valve b、清洗或更换吸水管 Clean or replace the pipe c、降低吸水高度 Lower it
3、压力表有压力而水泵仍不出水 There is a pressure shown on the pressure gauge, but no water is out of the pump	a、出水管阻力太大 Too big resistance with the water-out pipe b、旋转方向不对 Wrong rotating direction c、叶轮堵塞 The impeller is blocked up d、水泵转速不够 The pump speed is insufficient	a、清洗或缩短水管 Clean or shorten the pipe b、检查电机旋向 Check the motor's rotating direction c、清洗叶轮 Clean it d、增加水泵转速 Enhance it
4、泵流量减少或扬程下降 The pump's flow is reduced or head is lowered	a、叶轮或管路堵塞 The impeller or pipeline is blocked up b、密封环或叶轮磨损过多 Too much worn-out with the seal ring or the impeller c、转速不够 The speed is insufficient	a、清洗叶轮及管路 Clean both impeller and pipeline b、更换损坏零件 Replace the damaged parts c、调整到额定转速 Adjust it to the rated speed
5、水泵消耗的功率过大 Too big power consumption with the pump	a、填料压盖太紧，填料函发热 The packing gland is too tight, causing the packing heated b、叶轮与密封环摩擦 Friction exists between the impeller and the seal ring c、流量过大 Too big flow	a、放松填料压盖 Loosen the gland b、消除机械摩擦 Eliminate the mechanical friction c、关小出水闸阀 Close the water-out gate valve smaller
6、水泵内部声音反常，水泵吸不上水 Abnormal noise inside of the pump, the pump can not suck water in	a、吸水管内阻力过大 Too heavy resistance inside of the water suction pipe b、吸水管有空气漏入 Air goes into the water suction pipe c、流量过大发生汽蚀 Too heavy flow causes steam erosion	a、减小吸水高度缩短吸水管长度 Lower the water suction height, shorten the water suction pipe b、堵塞漏气处 Block up the air leaking place c、调节出口阀门使泵在规定工况范围内使用 Adjust the outlet valve to have the pump used within the set working conditions
7、水泵振动厉害 Severe vibration with the pump	a、泵发生汽蚀、叶轮不平衡 Steam erosion happens with the pump, the impeller is made unbalanced b、泵轴与电机不在同一中心线上 The shafts of both pump and motor are not on the same central line c、地脚螺栓松动 The foot bolt is loose	a、消除汽蚀、叶轮校平衡 Get rid of steam erosion and correct the impeller's balance b、校水泵和电机的同轴度 Correct the coaxiality between both pump and motor c、拧紧地脚螺栓 Tighten the foot bolt
8、轴承过热 The bearing is overheated	a、润滑油不足或过多，或变质 Insufficient or excessive lubricating oil, or it goes bad b、水泵与电机轴不同心 The shafts of both pump and motor are not on the same central line	a、检查油量，清洗轴承并换油 Check the oil amount, clean the bearing and replace the oil b、把轴中心线对准 Have the shaft's central line aligned

管路损失参考表 REFERENCE TABLE FOR PIPELINE LOSS

管径 Pipe diameter (mm)	流 量 Capacity (L/s)																							
	1	2	4	6	8	10																		
2.5	32.7	13.0																						
38	3.5	14	55				15	20																
50	0.8	3.1	13	29				25	30															
65		1.6	3.2	7.1	13	20			40	50														
75		0.4	0.8	3.3	5.9	9.6	21.6			60	70													
100			0.23	0.8	1.3	2.1	6.8	8.6	13		80	90												
125				0.23	0.4	0.63	1.3	2.7	4.1	5.9	10.7	110												
150					0.16	0.26	0.58	1.1	1.6	2.3	4.2	6.4	9.4											
175						0.11	0.27	0.5	0.74	1.05	1.9	2.9	4.3	5.8	7.7	9.6								
200							0.13	0.26	0.37	0.53	0.93	1.5	2.1	2.9	3.7	4.7	6.1	7.2	8.5	120	130			
250								0.07	0.12	0.18	0.30	0.48	0.68	0.93	1.2	1.5	1.9	2.3	2.8	3.3	4.9	5.2		
300										0.07	0.12	0.19	0.27	0.37	0.49	0.61	0.76	0.9	1.1	1.3	1.5	2.0	2.4	3.0

直管摩擦损失简表(供估计用)100m直管损失米数以新铸铁管为标准,旧管加倍。
Brief table for the frictional loss of a straight pipe(for evaluation), the lost meters of a 100m straight pipe takes the newly cast iron pipe as the standard and multiple for the old one.

阀及弯管折合直管长度 (每个)

The length of a straight pipe converted into from both valve and elbow(each)

种类 Variety	折合直管直径倍数 Convert into the times of the diameter of a straight pipe	备注 Remark
全开闸阀 Fully opened gate valve	13	未畅开加倍 Multiple in case of unopen
标准弯管 Standard elbow	25	
逆止阀 Back valve	100	
底阀 Foot valve	100	部分堵塞加倍 Partial block-up multiplied

注:例如100mm直径管,底阀折合100倍直径等于 $100 \times 100 = 10000\text{mm} = 10\text{m}$ 直径长度,假定流量为 8L/s ,直管每 100m 损失 1.3m ,则 10m 损失 0.13m ,即一个 100mm 底阀,流量为 8L/s 时,则损失扬程 0.13m 。

Note:For instance, a 100mm diameter pipe, the foot valve has a $100 \times 100 = 10000\text{mm} = 10\text{m}$ diameter when which is converted into 100 times that of the pipe's diameter. Suppose the flow is 8L/s , looked into the above table, the loss of the straight pipe is 1.3m each 100m , then the one for 100mm is 0.13m , that is, for a 100mm foot valve with a flow 8L/s , its head loss is 0.13m .

一定管路直径之最大流量限制

LIMIT OF THE MAXIMUM FLOW FOR A PIPE WITH A CERTAIN DIAMETER

管路直径 Pipeline diameter (mm)	最大流量 Maximum flow (L/s)	最大流速 Maximum flow rate (m/s)	管路直径 Pipeline diameter (mm)	最大流量 Maximum flow (L/s)	最大流速 Maximum flow rate (m/s)
25	1	2.04	125	30.0	2.44
38	2.5	1.69	150	43.0	2.45
50	4.17	2.12	175	60.0	2.49
65	6.67	2.01	200	83.3	2.69
75	10.0	2.26	250	133.0	2.72
100	18.4	2.33	300	192.0	2.71

注:超过此限使管路损失显著增加。
Note: The pipeline loss would be made greatly increased once the limit is over.