

# SP SPR 型液下渣浆泵



保定工业水泵制造有限公司

## 特点和用途

### Features and Applications

SP和SPR 型泵为立式离心渣浆泵，浸入液下，用于输送磨蚀性、粗颗粒、高浓度渣浆。不需要任何轴封和轴封水，在吸入量不足的工况下也能正常工作。

SP型泵泵体为耐磨金属，叶轮选用耐磨金属或橡胶、聚胺脂材料制造。

SPR型泵浸入液下的零部件均衬有橡胶，适用于输送腐蚀性渣浆。

Pumps of Type SP and Type SPR, the vertical centrifugal slurry pump, are submerged into solution and used to transport slurry with corrosion, coarse grain and high concentration. Without any shaft seal and shaft-seal water, it can work normally under the insufficient suction.

The pump body of Type SP is constructed of antifriction metal, and its impeller is constructed of antifriction metal, rubber or polyurethane.

The spare parts of Type SPR, submerged into water, are all lined with rubber and applicable of transporting corrosion slurry.

型号意义：

例如：40PV-SP（或SPR）

40-泵吐出口直径（毫米）

PV-立式托架

SP-液下渣浆泵

SPR-衬胶液下渣浆泵

Meaning of model:

For example: 40PV-SP (or SPR)

40- Diameter of pump outlet (mm)

PV-Tray

SP- Submerged slurry pump

SPR- Submerged slurry pump lined with rubber

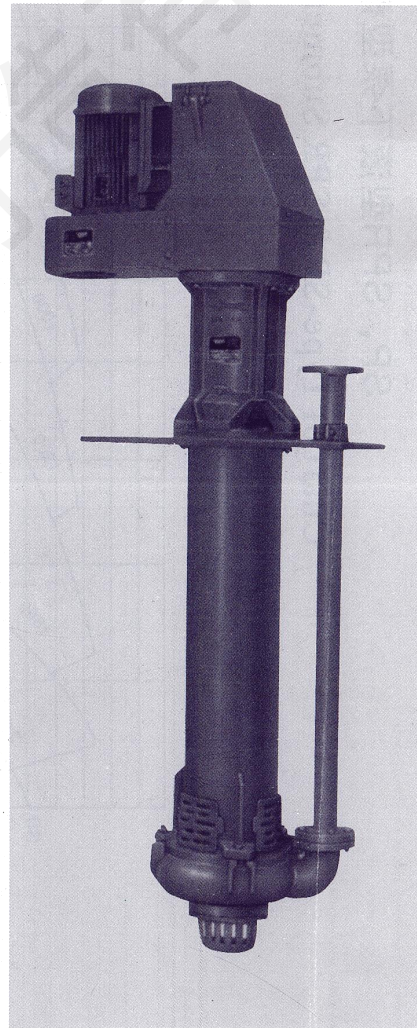

# SP, SPR型液下泵型谱

## Chart of Type-SP & SPR Submerged Pump

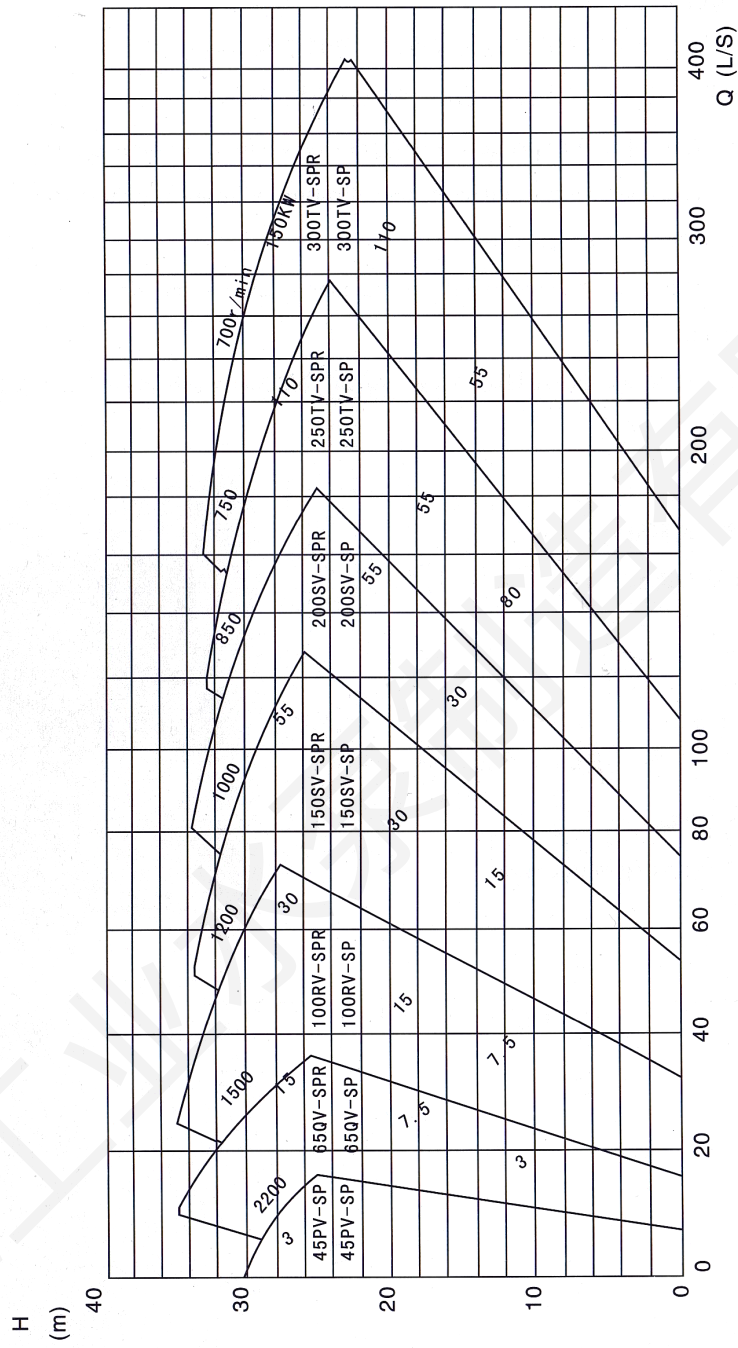

注：1、清水近似性能，仅供初步选型。

Note: similar performance in clear water, only for preliminary selection.

# SP, SPR型液下泵清水性能表

## Performance table of Type SP & SPR submerged pump in clear water

型号 Type	允许配代 最大功率 Allowable maximum power (kW)	材质 Materials		性能范围 Performance range					叶片数 Number of blades	叶轮外径 Impeller diameter (mm)	曲线编号 Curve No.
		护套 Jacket	叶轮 Impeller	流量 Q (m <sup>3</sup> /h)	扬程 H Head (m)	转速 Rev n (r/min)	最高效率 Max. Efficiency η %	汽蚀余量 NPSH (m)			
40PV-SP	15	M	M 或 PU	19.44~43.2	4.5~28.5	1000~2200	40		5	188	WPA40E41
40PV-SPR		RU	RU	17.28~39.6	4~26	1000~2200	40		5	188	WPA40E42
65QV-SP	30	M	PU	23.4~111	5~29.5	700~1500	50		5	280	WPA65E41
65QV-SP		M	M	19.8~93.06	5~29.5	700~1500	40		4	280	WPA65E42
65QV-SP		M	M	24.3~87.12	5.5~31.5	700~1500	58		5	280	WPA65E41A
65QV-SP		M	M	24.3~114.8	5~30	700~1500	60		5	280	WPA65E45
65QV-SPR		RU	RU	22.5~105	5.5~30.5	700~1500	51		5	280	WPA65E43
65QV-SP		M	M	18.9~89.1	5~28	700~1500	35		8	290	WPA65E44
100RV-SP	75	M	PU	56.7~221.76	4.5~34.5	500~1200	56		5	370	WPA100E41
100RV-SPR		RU	PU	64.8~285	7.5~36	600~1200	62		5	370	WPA100E42
100RV-SP		M	M	54~289	5~35	500~1200	56		5	370	WPA100E43
100RV-SP		M	M	54~237.6	6~30	600~1200	40		8	390	ESY8000
150SV-SP	110	M	PU	108~479.16	8.5~40	500~1000	52		5	450	WPA150E41
200SV-SP	110	M	M 或 PU	189~891	6.5~37	400~850	64		5	520	WPA200E41
250TV-SP	200	M	M 或 PU	261~1089	7.5~33.5	400~750	60		5	575	WPA250E41
300TV-SP	200	M	PU	288~1267	6.5~33	350~700	50		5	610	ESY7951

注：1、推荐流量范围为50%Q' ≤ Q ≤ 110%Q' (Q' ≈ 相当于最高效率点流量) 2、“PU”是聚氨酯材料。“M”是合金耐磨材料。“RU”是橡胶材料。  
 Note: 1. The recommended flow range: 50%Q' ≤ Q ≤ 110%Q' (Q' is approach to the flow on the maximum efficiency point).

2. PU is polyurethane material; M is wearproof alloy material; RU is rubber material.

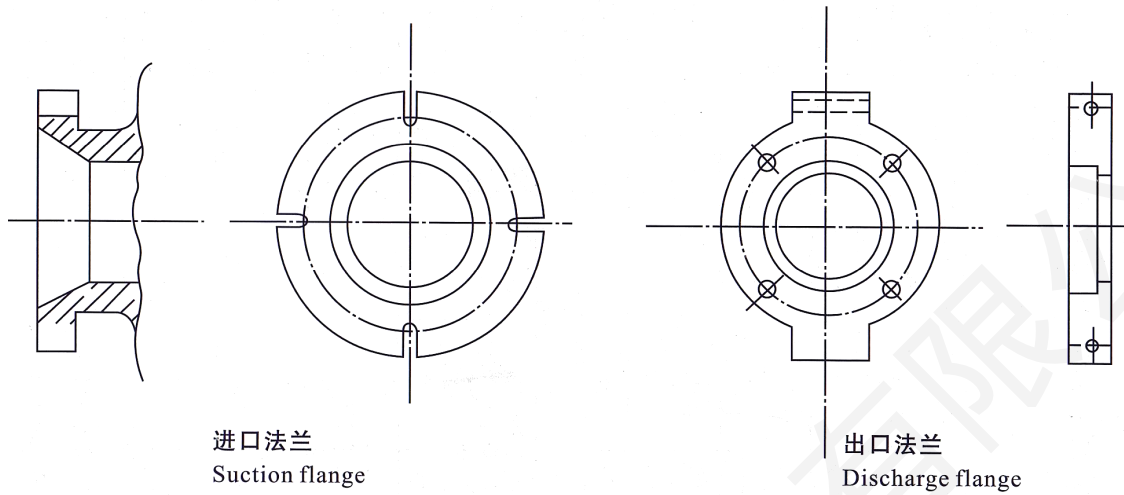

### 外形尺寸 Outline dimensions

型号 Type	进口法兰 Suction flange				出口法兰 Discharge flange			
	外径 O.D.	内径 I.D.	孔中心距 C/C for holes	孔 Holes	外径 O.D.	内径 I.D.	孔中心距 C/C for holes	孔 Holes
40PV SP SPR	φ 70	φ 81	φ 140	4-φ 14	φ 127	φ 40	φ 98	4-φ 16
65QV SP SPR	φ 240	φ 104	φ 215	4-φ 14	φ 178	φ 65	φ 140	4-φ 19
100RV SP SPR	φ 380	φ 175	φ 325	4-φ 24	φ 229	φ 100	φ 191	8-φ 19
150SV SP SPR					φ 280	φ 150	φ 214	8-φ 22
200SV SP SPR					φ 343	φ 200	φ 298	8-φ 22
250TV SP SPR					φ 406	φ 250	φ 362	12-φ 25
300TV SP SPR					φ 483	φ 300	φ 432	12-φ 25

## 结构图

Construction drawing

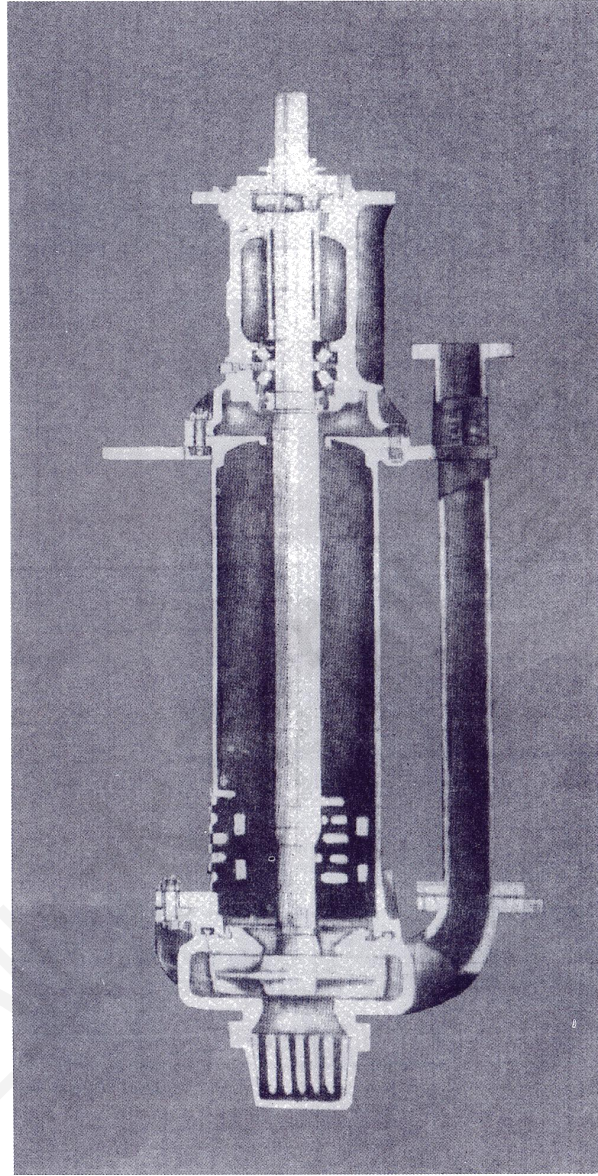

SP型是全部金属件，用于输送磨蚀性渣浆

Type SP adopts metal parts completely to transport abrasive slurry.

SPR型是橡胶保护，用于输送酸性磨蚀渣浆

Type SPR adopts rubber for protection to transport acid ablative slurry

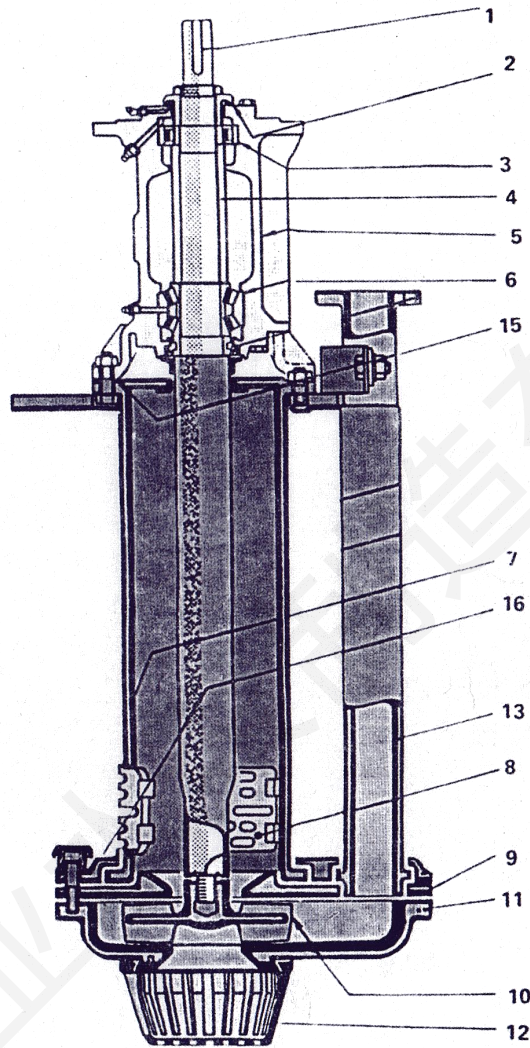

- 1、轴 2、迷宫套 3、轴承 4、轴承档套 5、轴承体 6、轴承 7、支架 8、滤网 9、后护板 10、叶轮  
 11、泵体 12、下滤网 13、吐出管 14、对开吐出法兰 15、调整垫 16、支架压紧盖
1. Shaft 2. Maze sleeve 3. Bearing 4. Bearing block sleeve 5. Bearing body 6. Bearing 7. Bracket 8. Strainer  
 9. Rear guard plate 10. Impeller 11. Pump body 12. Lower strainer 13. Discharge pipe 14. Split discharge flange  
 15. Adjust shim 16. Clamping cap

# 外形尺寸 Outline dimensions

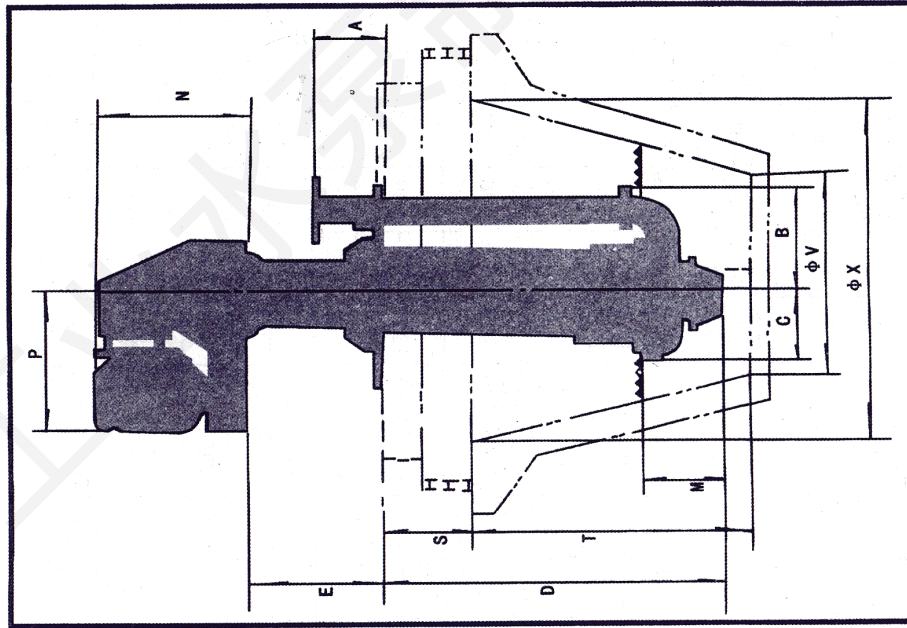

皮带传动  
Belt drive

直接联接传动  
Direct coupled drive

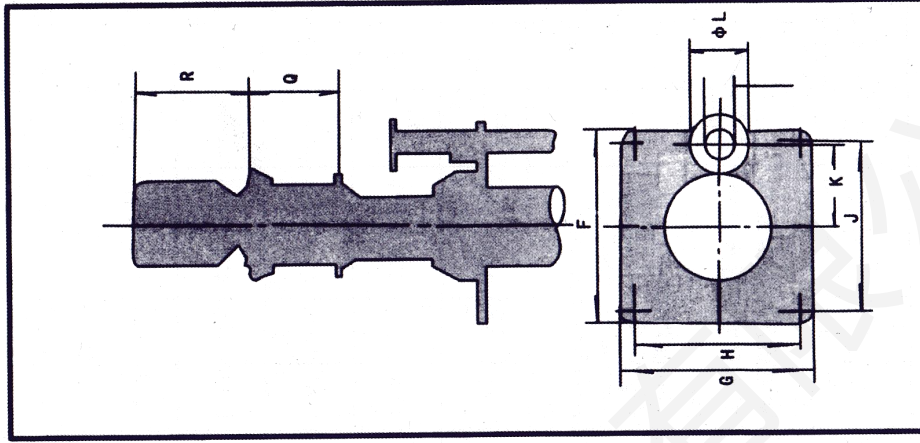

吐出口直径  
Discharge diameter

安装平面图  
Plane graph  
of installation



泵 Pump		A	B	C	D	E	F	G	H	J	K	φL	M	N	P	Q	R	泵重 Weight (kg)	渣浆池尺寸 Dimensions of slurry tank				
																			吐出口 直径 Discharge diameter	托架 Tray	型号 Type	S	T
40	PV	SP	137	285	153	380	500	500	450	450	205	127	174	733	675	248	692	285	280	695	550	1000	0.34
		SPR	140	265	175	380	500	500	450	450	205	127	174	733	675	248	692	285	280	695	550	1000	0.34
65	QV	SP	227	399	231	492	680	680	620	620	285	178	265	898	794	290	681	432	350	925	800	1400	0.90
		SPR	230	380	260	498	680	680	620	620	285	178	265	898	794	290	681	432	350	925	800	1400	0.90
100	RV	SP	260	538	317	662	1000	870	800	930	400	229	393	1141	1020	416	960	867	350	1225	1000	1750	1.86
		SPR	266	535	332	668	1000	870	800	930	400	229	393	1141	1020	416	960	867	350	1225	1000	1750	1.86
150	SV	SP	390	670	365	875	1100	1100	1030	1030	500	280	475	1311	1200	476	1011	1737	350	1525	1250	2150	3.54
		SPR	395	670	400	883	1100	1100	1030	1030	500	280	475	1311	1200	476	1011	1737	350	1525	1250	2150	3.54
200	SV	SP	450	805	400	878	1300	1200	1100	1200	600	343	550	1313	1300	476	1011	—	350	1525	1500	2400	4.76
		SPR	—	—	—	1800	1300	1200	1100	1200	600	343	550	1313	1300	476	1011	—	350	1525	1500	2400	4.76
250	TV	SP	500	930	470	1000	1750	1450	1350	1650	700	406	685	1572	1750	561	1246	—	400	1775	1700	2700	6.86
		SPR	—	—	—	2100	1750	1450	1350	1650	700	406	685	1572	1750	561	1246	—	400	1775	1700	2700	6.86
300	TV	SP	500	1170	559	1000	1750	1450	1350	1650	700	483	700	1467	1750	561	1246	—	400	1800	2000	3100	9.34
		SPR	400	1090	630	1365	1750	1450	1350	1650	700	483	700	1467	1750	561	1246	—	400	1800	2000	3100	9.34

始于客户所需 终于客户满意



保定上...有限公司